

## ACM8628 2×41W Stereo | 1×82W Mono, Digital Input Class-D Audio Amplifier with Rich Audio Effect Tuning

### 1. Features

- Flexible Power Supply Configurations
  - PVDD: 4.5V to 26.4V
  - DVDD and I/O: 3.3V
- Various output configurations
  - 2×41W, Stereo mode (6Ω, 24V, THD+N = 1%)
  - 2×33W, Stereo mode (4Ω, 18V, THD+N = 1%)
  - 1×82W, Mono mode (3Ω, 24V, THD+N = 1%)
- Excellent Audio Performance
  - THD+N ≤ 0.03% at 1W, 1kHz, PVDD = 12V
  - 114 dB A-weighted signal-to-noise ratio (SNR)
  - Idle switching A-weighted noise ≤ 37  $\mu V_{RMS}$
  - 28 mA low quiescent current @ PVDD=12V
  - 91.7% efficiency into 6Ω load ,PVDD=20V,2×28W
- Configurable digital audio interface
  - I<sup>2</sup>C control with up to 4 selectable addresses
  - I<sup>2</sup>S, Left-justified, Right-justified, TDM audio format
  - 3-Wire digital audio interface without MCLK required
  - 32kHz, 44.1kHz/48kHz, 88.2kHz/96kHz, 176.4kHz/192kHz input sample rate
  - SDOOUT for Acoustic Echo Cancellation – AEC or 1.1 / 2.1 system sub-channel signal routing
- Advanced audio effect tuning
  - Flexible digital and analog gain adjustment
  - High pass filter for DC blocking
  - Input signal router for left and right channel
  - 2×15 pre BQs & 2×5 post BQs to support enhanced audio frequency tuning
  - Pre volume & post volume for dynamic headroom and loudness control
  - 3 band dynamic range control (DRC) with time delay buffer & post compensation BQs for flexible and flat multiple band control
- Analog protections
  - FAULT status report through GPIO and I<sup>2</sup>C registers
  - Over current and Direct current protection
  - Over temperature protection
  - Under-voltage and Over-voltage protection

- Clock error protection

### 2. Applications

- Portable Speakers: Bluetooth, Smart Speakers with Voice Assistant
- Home Audio: TV, Soundbar, STB (set top box), HTiB (Home Theatre in a Box)
- PCs and Laptops

### 3. General Description

ACM8628 is a fully integrated, high efficiency, stereo Class-D audio amplifier with digital inputs. The application circuit requires few passives components to operate with 4.5V to 26.4V PVDD supply, 3.3V DVDD supply. It can drive 2×41W output power into BTL 6Ω and 1×82W into PBTL 3Ω@1% THD+N.

ACM8628 features one novel PWM modulation architecture, which adjusts PWM common duty cycle during start-up phase to avoid startup pop click.

Spread spectrum technology provides lower EMI radiated emissions. It allows inductor free application with specified output power situation with ACM8628.

The advanced audio effect tuning capability inside ACM8628 provides one highly integrated solution. It allows turning on / off each block with highly free operations. Both pre and post BQs / volume helps a lot to maintain audio headroom. Furthermore, 3 band DRC with time delay buffer and post compensation BQs is available to implement flexible and flat multiple band control.

### 4. Device Information

Part number	Package	Body size
ACM8628	TSSOP 28	9.7 mm × 4.4 mm

## 5. Pin Configuration and Function Descriptions

### ACM8628 TSSOP 28 Pin

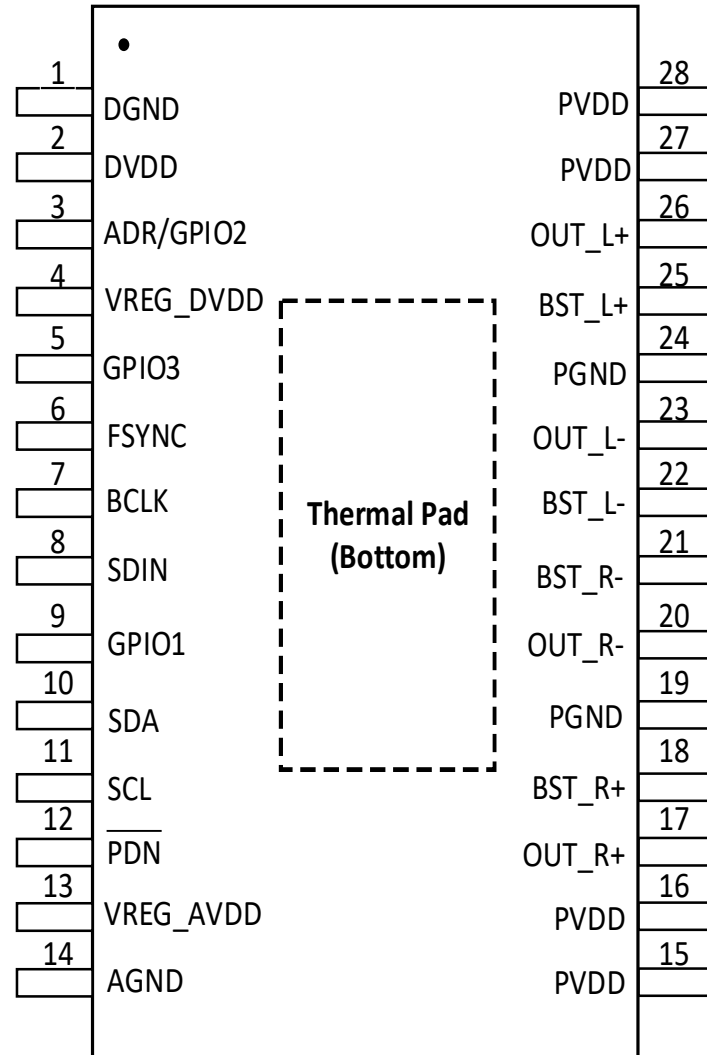

Pin No.	Name	Type	Description
1	DGND	PWR	Digital Ground.
2	DVDD	PWR	Digital power supply input: 3.3V.
3	ADR/GPIO2	DIO	I <sup>2</sup> C address selection / GPIO2: FAULT / WARNING / SDOUT...
4	VREG_DVDD	AOUT	Digital regulator output.
5	GPIO3	DIO	GPIO3: FAULT / WARNING / SDOUT... Default setting is allowed to directly short to GND.
6	FSYNC	DIN	Word select clock for the digital signal.
7	BCLK	DIN	Bit clock for the digital signal.
8	SDIN	DIN	Serial data input.
9	GPIO1	DIO	GPIO1: FAULT / WARNING / SDOUT...

10	SDA	DIO	I <sup>2</sup> C serial data.
11	SCL	DIN	I <sup>2</sup> C clock.
12	$\overline{P\overline{DN}}$	DIN	Shut down, low active.
13	VREG_AVDD	AOUT	Analog regulator output.
14	AGND	PWR	Analog ground.
15	PVDD	PWR	Power stage supply input.
16	PVDD	PWR	Power stage supply input.
17	OUT_R+	AOUT	Right channel positive output of H-bridge.
18	BST_R+	AIN	Bootstrap capacitor for OUT_R+.
19	PGND	PWR	Power stage ground.
20	OUT_R-	AOUT	Right channel negative output of H-bridge.
21	BST_R-	AIN	Bootstrap capacitor for OUT_R-.
22	BST_L-	AIN	Bootstrap capacitor for OUT_L-.
23	OUT_L-	AOUT	Left channel negative output of H-bridge.
24	PGND	PWR	Power stage ground.
25	BST_L+	AIN	Bootstrap capacitor for OUT_L+.
26	OUT_L+	AOUT	Left channel positive output of H-bridge.
27	PVDD	PWR	Power stage supply input.
28	PVDD	PWR	Power stage supply input.

## 6. Device Family Comparison

Device Name	$R_{dson}$	PVDD	Output Power
ACM8615	135 mΩ	4.5V ~ 21V	Mono 1×21W (8Ω, 20V, THD+N = 1%)
ACM8625M	135 mΩ	4.5V ~ 26.4V	Stereo 2×26W (8Ω, 22V, THD+N = 1%)
ACM8628	75 mΩ	4.5V ~ 26.4V	Stereo 2×41W (6Ω, 24V, THD+N = 1%)

## 7. Specifications

### 7.1 Absolute Maximum Ratings <sup>(1)</sup>

		MIN	MAX	UNIT
DVDD	Low-voltage digital supply	-0.3	3.9	V
PVDD	PVDD supply	-0.3	30	V
V <sub>I(DIGIN)</sub>	DVDD referenced digital inputs <sup>(2)</sup>	-0.5	V <sub>DVDD</sub> +0.5	V
V <sub>I(OUTXX)</sub>	Voltage at speaker output pins	-0.3	32	V
T <sub>A</sub>	Ambient operating temperature	-25	85	°C
T <sub>stg</sub>	Storage temperature	-40	125	°C

(1) Stressed beyond those listed under Absolute Maximum Ratings may cause permanent damage to the device. These are stress ratings only, which do not imply functional operation of the device at these or any other conditions beyond those indicated under Recommended Operating Conditions. Exposure to absolute-maximum-rated conditions for extended periods may affect device reliability.

(2) DVDD referenced digital pins include: GPIO3, ADR/GPIO2, FSYNC, BCLK, SDIN, GPIO1, SDA, SCL,  $\overline{\text{PDN}}$ .

### 7.2 ESD Ratings

			VALUE	UNIT
V <sub>(ESD)</sub>	Electrostatic discharge	Human-body model (HBM), per ANSI/ESDA/ JEDEC JS-001 <sup>(1)</sup>	±2000	V
		Charged-device model (CDM), per JEDEC specification JESD22-C101 <sup>(2)</sup>	±500	

(1) JEDEC document JEP155 states that 500-V HBM allows safe manufacturing with a standard ESD control process.

(2) JEDEC document JEP157 states that 250-V CDM allows safe manufacturing with a standard ESD control process.

### 7.3 Recommended Operating Conditions

Over operating free-air temperature range (unless otherwise noted)

		MIN	NOM	MAX	UNIT	
V <sub>(SUPPLY)</sub>	Power supply inputs	DVDD	2.8		3.63	V
		PVDD	4.5		26.4	
	Recommended PVDD Range	BTL Mode, Speaker Load=4Ω (+/-20% Variation)	4.5		19	V
		BTL Mode, Speaker Load=6Ω (+/-20% Variation)	4.5		26.4	
		BTL Mode, Speaker Load=8Ω (+/-20% Variation)	4.5		26.4	
		PBTL Mode, Speaker Load=2Ω (+/-20% Variation)	4.5		19	
		PBTL Mode, Speaker Load=3Ω (+/-20% Variation)	4.5		26.4	
		PBTL Mode, Speaker Load=4Ω (+/-20% Variation)	4.5		26.4	
V <sub>IH(DIGIN)</sub>	Input logic high for DVDD reference digital inputs	0.9×DVDD		DVDD	V	
V <sub>IL(DIGIN)</sub>	Input logic low for DVDD reference digital inputs			0.1×DVDD		
L <sub>OUT</sub>	Minimal inductor value in LC filter under short-circuit condition	1			μH	
T <sub>J</sub>	Junction Operating Temperature	-40		150	°C	
T <sub>A</sub>	Ambient Operating Temperature	-40		85	°C	

## 7.4 Thermal Information

		ACM8628 TSSOP 28 PINS	UNIT
		JEDEC STANDARD 4-LAYER PCB	
$\theta_{JA}$	Junction-to-ambient thermal resistance	28	°C/W
$\theta_{JT}$	Junction-to-case (top) thermal resistance	22	°C/W
$\psi_{JT}$	Junction-to-top characterization parameter	1.2	°C/W

## 7.5 Electrical Characteristics

Free-air room temperature 25° C, LPD mode, LC filter=10uH+0.68uF, Fsw=480kHz, (unless otherwise noted)

PARAMETER	TEST CONDITIONS	MIN	TYP	MAX	UNIT
<b>DIGITAL I/O</b>					
I <sub>IH</sub>	Input logic high current level for DVDD referenced digital input pins	V <sub>IN(Digin)</sub> =V <sub>DVDD</sub>		10	μA
I <sub>IL</sub>	Input logic low current level for DVDD referenced digital input pins	V <sub>IN(Digin)</sub> =0 V		-10	μA
V <sub>IH(Digin)</sub>	Input logic high threshold for DVDD referenced digital inputs		70%		V <sub>DVDD</sub>
V <sub>IL(Digin)</sub>	Input logic low threshold for DVDD referenced digital inputs			30%	V <sub>DVDD</sub>
V <sub>OH(Digin)</sub>	Output logic high threshold for DVDD referenced digital inputs	I <sub>OH</sub> = 2mA	80%		V <sub>DVDD</sub>
V <sub>OL(Digin)</sub>	Output logic low threshold for DVDD referenced digital inputs	I <sub>OH</sub> = -2mA		20%	V <sub>DVDD</sub>
<b>I<sup>2</sup>C CONTROL PORT</b>					
C <sub>L(I2C)</sub>	Allowable load capacitance for each I <sup>2</sup> C line			400	pF
F <sub>SCL(fast)</sub>	Support SCL frequency	No wait states, fast mode		400	kHz
F <sub>SCL(slow)</sub>	Support SCL frequency	No wait states, slow mode		100	kHz
<b>SERIAL AUDIO PORT</b>					
t <sub>DLY</sub>	Required FSYNC to BCLK rising edge delay		5		ns
D <sub>SCLK</sub>	Allowable SCLK duty cycle		40%	60%	
f <sub>s</sub>	Supported input sample rates		32	192	kHz
F <sub>BCLK</sub>	Supported BCLK frequencies		32	64	f <sub>s</sub>
<b>AMPLIFIER OPERATING MODE AND DC PARAMETERS</b>					
t <sub>OFF</sub>	Turn-off Time	Excluding volume ramp		10	ms
A <sub>V(SPK_AMP)</sub>	Programmable Gain	Value represents the 'peak voltage' disregarding clipping due to lower PVDD Measured at 0dB input (1FS)	4.95	29.5	V <sub>peak</sub> /FS
ΔA <sub>V(SPK_AMP)</sub>	Amplifier gain error	Gain=29.5V <sub>P</sub> /FS		0.5	dB
F <sub>SW</sub>	Switching frequency of the speaker amplifier			384	kHz
				480	kHz
				576	kHz
				768	kHz
R <sub>DS(ON)</sub>	Drain-to-source on resistance	FET + Metallization. V <sub>PVDD</sub> =24V,		75	mΩ

PARAMETER		TEST CONDITIONS	MIN	TYP	MAX	UNIT
	of the individual output MOSFETs	$I_{(OUT)}=500\text{mA}$ , $T_J=25^\circ\text{C}$				
<b>PROTECTION</b>						
$OCE_{THRES}$	Over-Current Error Threshold	Speaker Output Current (Post LC filter), Speaker current, $PVDD=24\text{V}$ (100Hz Burst on, 500 cycles interval), LC filter= $10\mu\text{H}+0.68\mu\text{F}$ , $F_{sw}=480\text{kHz}$	6.5	7.5		A
$UVE_{THRES(PVDD)}$	PVDD under voltage error threshold			4		V
$OVE_{THRES(PVDD)}$	PVDD over voltage error threshold			28.2		V
$DCE_{THRES}$	Output DC Error protection threshold	Class D Amplifier's output DC voltage cross speaker load to trigger Output DC Fault protection		1.9		V
$T_{DCDET}$	Output DC Detect time	Class D Amplifier's output remain at or above $DCE_{THRES}$		570		ms
$OTE_{THRES}$	Over temperature error threshold			160		$^\circ\text{C}$
$OTE_{Hysteresis}$	Over temperature error hysteresis			10		$^\circ\text{C}$
$OTW_{THRES}$	Over temperature warning level			130		$^\circ\text{C}$
<b>AUDIO PERFORMANCE (STEREO BTL)</b>						
$ V_{OS} $	Amplifier offset voltage	Measure differentially with zero input data, programmable gain configured with 29.5Vp/FS, $V_{PVDD}=20\text{V}$	-10		10	mV
$P_{O(SPK)}$	Output Power (Per Channel) (LPD Mode, $F_{sw}=480\text{kHz}$ )	$V_{PVDD}=18\text{V}$ , $R_{SPK}=6\Omega$ , $f=1\text{kHz}$ , $\text{THD+N}=10\%$		30.72		W
		$V_{PVDD}=18\text{V}$ , $R_{SPK}=6\Omega$ , $f=1\text{kHz}$ , $\text{THD+N}=1\%$		24.6		W
		$V_{PVDD}=18\text{V}$ , $R_{SPK}=4\Omega$ , $f=1\text{kHz}$ , $\text{THD+N}=10\%$		42.41		W
		$V_{PVDD}=18\text{V}$ , $R_{SPK}=4\Omega$ , $f=1\text{kHz}$ , $\text{THD+N}=1\%$		33.5		W
		$V_{PVDD}=24\text{V}$ , $R_{SPK}=6\Omega$ , $f=1\text{kHz}$ , $\text{THD+N}=10\%$		52		W
		$V_{PVDD}=24\text{V}$ , $R_{SPK}=6\Omega$ , $f=1\text{kHz}$ , $\text{THD+N}=1\%$		41		W
$\text{THD+N}_{SPK}$	Total harmonic distortion and noise ( $P_O=1\text{W}$ , $f=1\text{kHz}$ , $R_{SPK}=6\Omega$ , LPD Mode, $F_{sw}=480\text{kHz}$ )	$V_{PVDD}=18\text{V}$		0.022		%
		$V_{PVDD}=24\text{V}$		0.021		%
$\text{ICN}_{(SPK)}$	Idle channel noise (A-Weighted, AES17)	$V_{PVDD}=18\text{V}$ , LC filter= $10\mu\text{H}+0.68\mu\text{F}$ , Load= $6\Omega$ , LPD Mode		37.1		$\mu\text{Vrms}$
		$V_{PVDD}=18\text{V}$ , LC filter= $10\mu\text{H}+0.68\mu\text{F}$ , Load= $6\Omega$ , High Performance Mode		38.2		$\mu\text{Vrms}$
DR	Dynamic range	A-Weighted, -60dBFS method. $V_{PVDD}=24\text{V}$ , Analog Gain=29.5Vp/FS		111		dB
SNR	Signal-to-noise ratio	A-Weighted, reference to 1% THD+N Output Level, $V_{PVDD}=24\text{V}$		114		dB
PSRR	Power supply rejection ratio	Injected Noise=1kHz, 1Vrms, $V_{PVDD}=18\text{V}$ , input audio signal=digital zero		72		dB
$X\text{-talk}_{SPK}$	Cross-talk (worst case between left-to-right and right-to-left channel)	$f=1\text{kHz}$ , $V_{PVDD}=24\text{V}$ , Load= $6\Omega$		90		dB
<b>AUDIO PERFORMANCE (MONO PBTL)</b>						
$ V_{OS} $	Amplifier offset voltage	Measure differentially with zero input data, programmable gain configured with 29.5Vp/FS, $V_{PVDD}=24\text{V}$	-10		10	mV
$P_{O(SPK)}$	Output Power	$V_{PVDD}=24\text{V}$ , $R_{SPK}=3\Omega$ , $f=1\text{kHz}$ , $\text{THD+N}=1\%$		82		W
		$V_{PVDD}=24\text{V}$ , $R_{SPK}=3\Omega$ , $f=1\text{kHz}$ , $\text{THD+N}=10\%$		105		W

PARAMETER		TEST CONDITIONS	MIN	TYP	MAX	UNIT
		V <sub>PVDD</sub> =24V, R <sub>SPK</sub> =4Ω, f=1kHz, THD+N=1%		67.57		W
		V <sub>PVDD</sub> =24V, R <sub>SPK</sub> =4Ω, f=1kHz, THD+N=10%		83		W
THD+N <sub>SPK</sub>	Total harmonic distortion and noise (P <sub>O</sub> =1W, f=1kHz)	V <sub>PVDD</sub> =24V, LC filter, R <sub>SPK</sub> =3Ω, LPD Mode		0.027		%
DR	Dynamic range	A-Weighted, -60dBFS method, V <sub>PVDD</sub> =24V, R <sub>SPK</sub> =3Ω		115		dB
SNR	Signal-to-noise ratio	A-Weighted, reference to 1% THD+N Output Level, V <sub>PVDD</sub> =24V, R <sub>SPK</sub> =3Ω		117		dB
ICN <sub>(SPK)</sub>	Idle channel noise (A-Weighted, AES17)	V <sub>PVDD</sub> =24V, LC filter=10uH+0.68uF, Load=4Ω, High Performance Mode		37		μVrms
PSRR	Power supply rejection ratio	V <sub>PVDD</sub> =18V, LC filter=10uH+0.68uF, Load=3Ω, High Performance Mode		72		dB

## 7.6 Timing Requirements

		MIN	NOM	MAX	UNIT
Serial Audio Port Timing-Slave Mode					
f <sub>BCLK</sub>	BCLK frequency	1.024			MHz
t <sub>BCLK</sub>	BCLK period	40			ns
t <sub>BCLKL</sub>	BCLK pulse width, low	16			ns
t <sub>BCLKH</sub>	BCLK pulse width, high	16			ns
t <sub>BF</sub>	BCLK rising to FSYNC edge	8			ns
t <sub>FB</sub>	FSYNC Edge to BCLK rising ed	8			ns
t <sub>SU</sub>	Data setup time, before BCLK rising edge	8			ns
t <sub>DH</sub>	Data hold time, after BCLK rising edge	8			ns
t <sub>DFB</sub>	Data delay time from BCLK failing edge		30		ns
I <sup>2</sup> C Bus Timing-Standard					
f <sub>SCL</sub>	SCL clock frequency			100	kHz
t <sub>BUF</sub>	Bus free time between a STOP and START condition	4.7			μs
t <sub>LOW</sub>	Low period of the SCL clock	4.7			μs
t <sub>HI</sub>	High period of the SCL clock	4			μs
t <sub>RS-SU</sub>	Setup time for (repeated) START condition	4.7			μs
t <sub>S-HD</sub>	Hold time for (repeated) START condition	4			μs
t <sub>D-SU</sub>	Data setup time	250			ns
t <sub>D-HD</sub>	Data hold time	0		3450	ns
t <sub>SCL-R</sub>	Rise time of SCL signal			1000	ns
t <sub>SCL-R1</sub>	Rise time of SCL signal after a repeated START condition and after an acknowledge bit			1000	ns
t <sub>SCL-F</sub>	Fall time of SCL signal			1000	ns
t <sub>SDA-R</sub>	Rise time of SDA signal			1000	ns
t <sub>SDA-F</sub>	Fall time of SDA signal			1000	ns
t <sub>P-SU</sub>	Setup time for STOP condition	4			μs
C <sub>B</sub>	Capacitive load for each bus line			400	pf
I <sup>2</sup> C Bus Timing-Fast					
f <sub>SCL</sub>	SCL clock frequency			400	kHz
t <sub>BUF</sub>	Bus free time between a STOP and START condition	1.3			μs

		MIN	NOM	MAX	UNIT
$t_{LOW}$	Low period of the SCL clock	1.3			$\mu$ s
$t_{HI}$	High period of the SCL clock	600			ns
$t_{RS-SU}$	Setup time for (repeated) START condition	600			ns
$t_{RS-HD}$	Hold time for (repeated) START condition	600			ns
$t_{D-SU}$	Data setup time	100			ns
$t_{D-HD}$	Data hold time	0		900	ns
$t_{SCL-R}$	Rise time of SCL signal	$20+0.1C_B$		300	ns
$t_{SCL-R1}$	Rise time of SCL signal after a repeated START condition and after an acknowledge bit	$20+0.1C_B$		300	ns
$t_{SCL-F}$	Fall time of SCL signal	$20+0.1C_B$		300	ns
$t_{SDA-R}$	Rise time of SDA signal	$20+0.1C_B$		300	ns
$t_{SDA-F}$	Fall time of SDA signal	$20+0.1C_B$		300	ns
$t_{P-SU}$	Setup time for STOP condition	600			ns
$t_{SP}$	Pulse width of spike suppressed			50	ns
$C_B$	Capacitive load for each bus line			400	pf

### 7.7 Timing Parametric Requirements Information

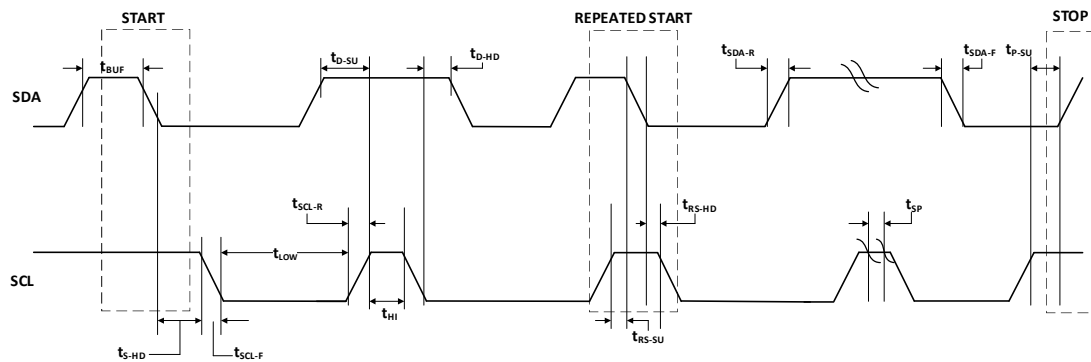

Figure 1 I<sup>2</sup>C Communication Port Timing Diagram

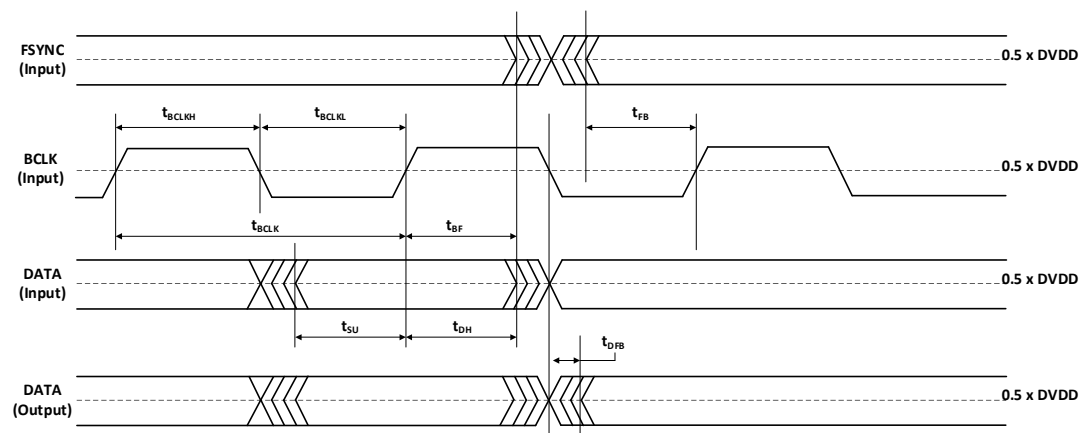

Figure 2 Serial Audio Port Timing in Slave Mode

## 8. Idle Power Dissipation

### 8.1 DVDD Current

Fs=480kHz, Free-are room temperature 25° C.

**Table 1 DVDD Current**

DVDD (V)	Device Mode	Current Consumption (mA)	Setting Register Location
3.3	Play Mode (DSP Enable)	30.65	Register 0x04
	Play Mode (DSP Bypass)	13.066	Register 0x04 and Register 0x05
	Driver-off (DSP Enable)	30.375	Register 0x04
	Driver-off (DSP Bypass)	12.798	Register 0x04
	Analog-off	0.933	Register 0x04
	Digital-off	0.848	Register 0x04
	$\overline{\text{PDN}}=0$	0.007	Pin 12 pulled to low

### 8.2 PVDD Current

Fs=480kHz, Free-are room temperature 25° C. LC Filter=10uH+0.68uF, Fsw=480khz, LPD Mode.

**Table 2 PVDD Current**

PVDD (V)	Device Mode	Current Consumption (mA)	Setting Register Location
7.4	Play	22	Register 0x04
	Driver-off	9.593	
	Analog-off	5.897	
	Digital-off	0.0924	
	$\overline{\text{PDN}}=0$	0.0062	Pin 12 pulled to low
12	Play	27.7	Register 0x04
	Driver-off	9.623	
	Analog-off	5.943	
	Digital-off	0.0934	
	$\overline{\text{PDN}}=0$	0.0069	Pin 12 pulled to low
16	Play	33.26	Register 0x04
	Driver-off	9.67	
	Analog-off	5.998	
	Digital-off	0.0938	
	$\overline{\text{PDN}}=0$	0.0075	Pin 12 pulled to low
18.5	Play	37	Register 0x04
	Driver-off	9.705	
	Analog-off	6.035	
	Digital-off	0.0944	
	$\overline{\text{PDN}}=0$	0.0082	Pin 12 pulled to low
24	Play	46	Register 0x04
	Driver-off	9.787	

	Analog-off	6.112	
	Digital-off	0.098	
	$\overline{\text{PDN}}=0$	0.009	Pin 12 pulled to low

### 9. Typical Characteristics

#### 9.1 Bridge Tied Load (BTL) Configuration Curves with LPD Mode

Free-air room temperature 25°C (unless otherwise noted.) Measurements were made using ACM8628 EVM board and Audio Precision System 2722 with Analog Analyzer filter set to 20-kHz brickwall filter. Device PWM Modulator mode set to LPD (Low Power Dissipation) mode with Class D Bandwidth =105kHz for 480kHz Fsw.

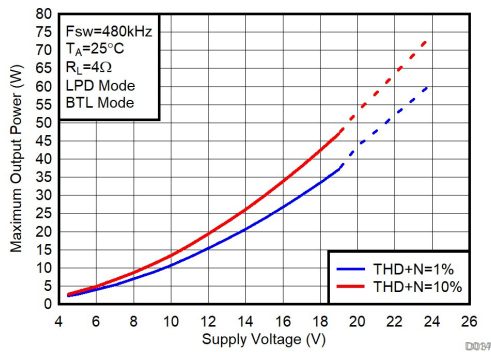

(Load=4Ω, Fsw=480kHz, LPD Mode)

Note: Dash line means not recommended due to thermal

Figure 3 Output Power vs PVDD

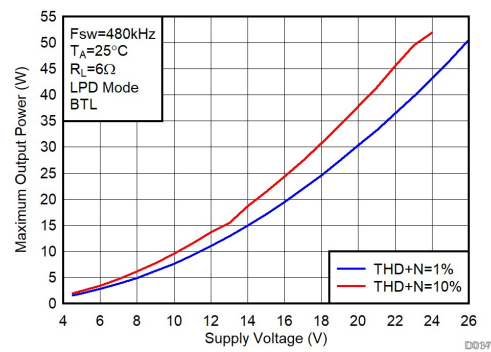

(Load=6Ω, Fsw=480kHz, LPD Mode)

Note: Dash line means not recommended due to thermal

Figure 4 Output Power vs PVDD

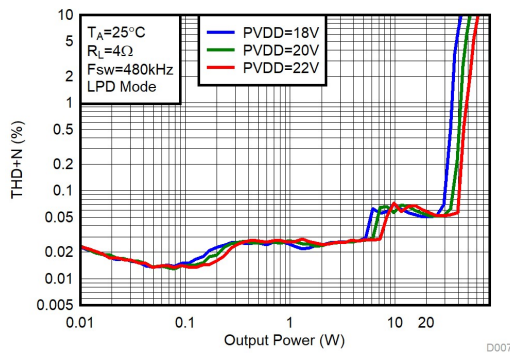

(Load=4Ω, Fsw=480kHz, LPD Mode)

Figure 5 THD+N vs Output Power

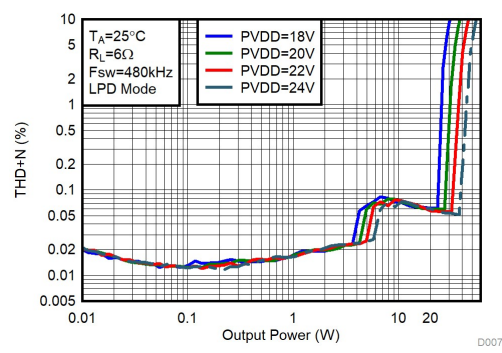

(Load=6Ω, Fsw=480kHz, LPD Mode)

Figure 6 THD+N vs Frequency

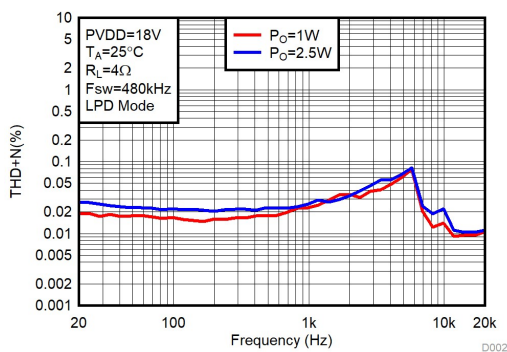

(PVDD=18V, Load=4Ω, Fsw=480kHz)

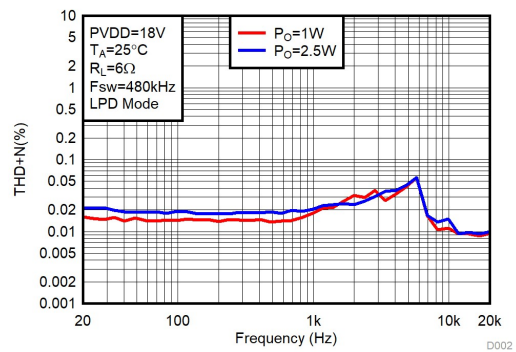

(PVDD=18V, Load=6Ω, Fsw=480kHz)

Figure 7 THD+N vs Frequency

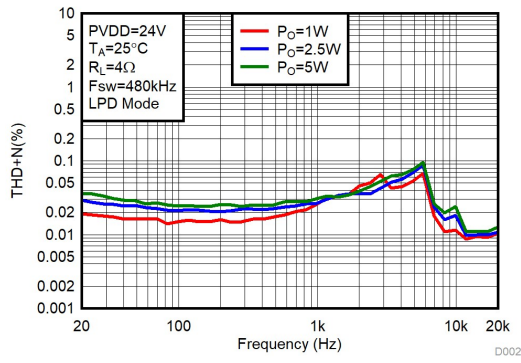

(PVDD=24V, Load=4Ω, Fsw=480kHz)

Figure 8 THD+N vs Frequency

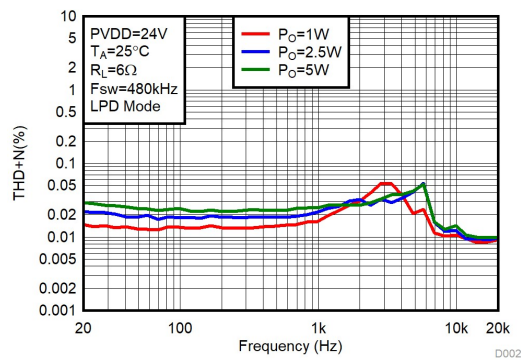

(PVDD=24V, Load=6Ω, Fsw=480kHz)

Figure 9 THD+N vs Frequency

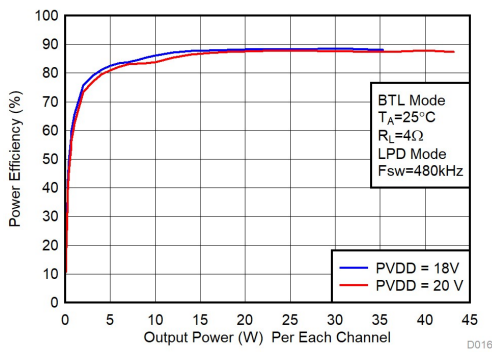

(Load=4Ω, Fsw=480kHz, LPD Mode)

Figure 11 Efficiency vs Output Power

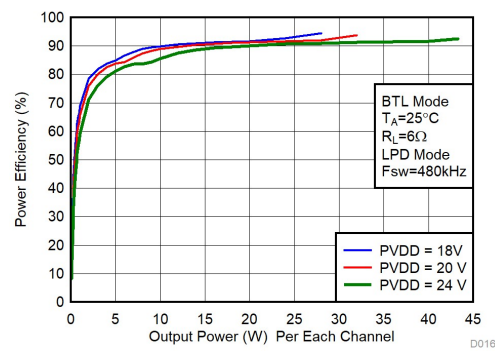

(Load=6Ω, Fsw=480kHz, LPD Mode)

Figure 12 Efficiency vs Output Power

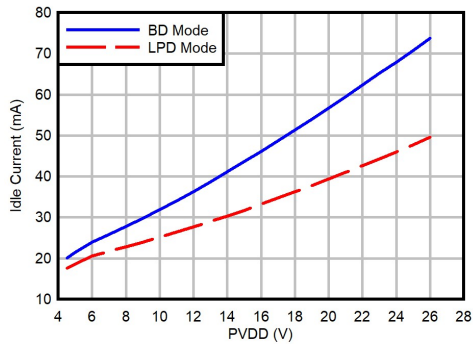

(Fsw=480kHz, LC Filter=10uH+0.68uF)

Figure 13 Idle Current vs PVDD

## 9.2 Parallel Bridge Tied Load (PBTL) Configuration Curves with LPD Mode

Free-air room temperature 25°C (unless otherwise noted.) Measurements were made using ACM8628 EVM board and Audio Precision System 2722 with Analog Analyzer filter set to 20-kHz brickwall filter. Device PWM Modulator mode set to LPD mode with Class D Bandwidth =105kHz for 480kHz Fsw.

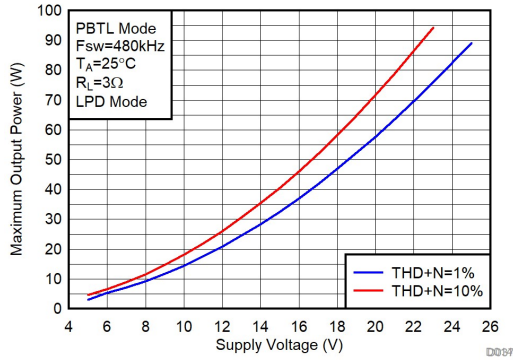

(Load=3Ω, Fsw=480kHz, LPD Mode)

Figure 14 Output Power vs PVDD

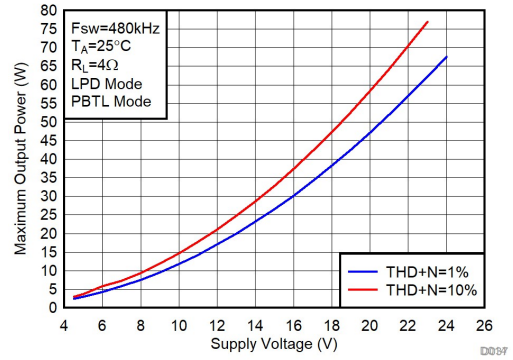

(Load=4Ω, Fsw=480kHz, LPD Mode)

Figure 15 Output Power vs PVDD

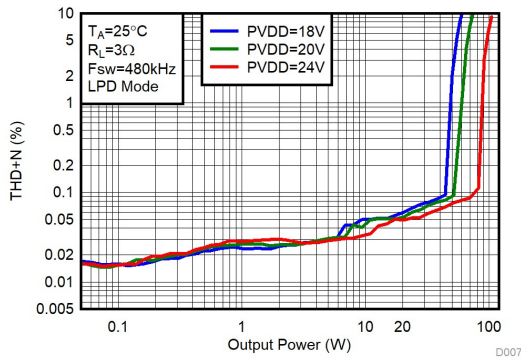

(Load=3Ω, Fsw=480kHz, LPD Mode)

Figure 16 THD+N vs Output Power

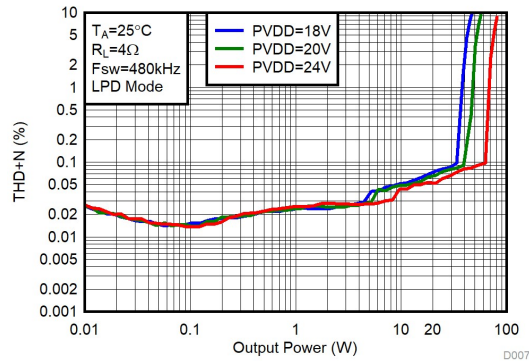

(Load=4Ω, Fsw=480kHz, LPD Mode)

Figure 17 THD+N vs Output Power

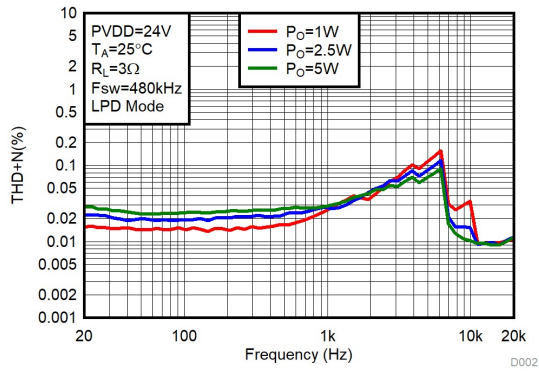

(Load=3Ω, Fsw=480kHz, LPD Mode)

Figure 18 THD+N vs Frequency

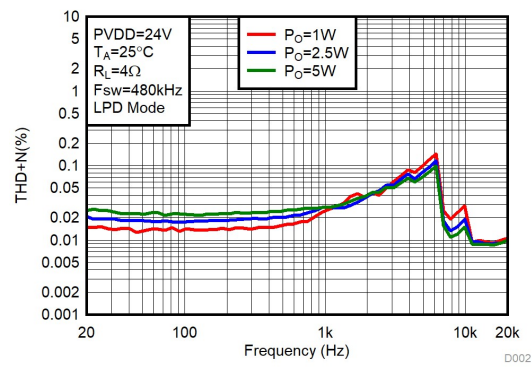

(Load=4Ω, Fsw=480kHz, LPD Mode)

Figure 19 THD+N vs Frequency

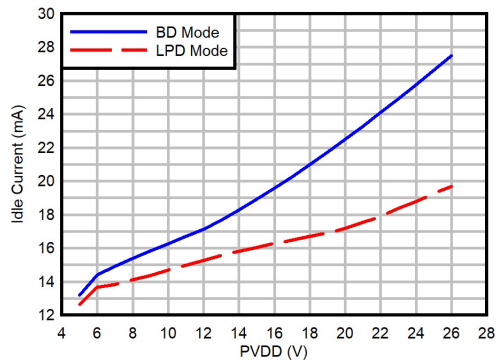

(Fsw=480kHz, LC Filter=10uH+0.68uF)

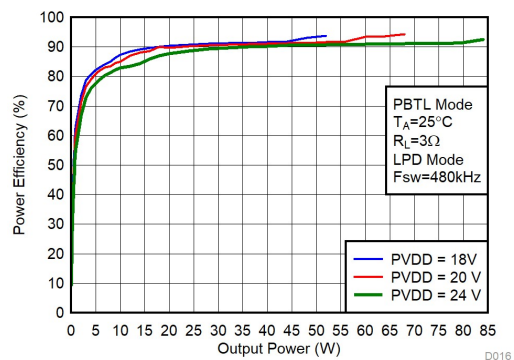

(Load=3Ω, Fsw=480kHz, LPD Mode)

Figure 20 Idle Current vs PVDD

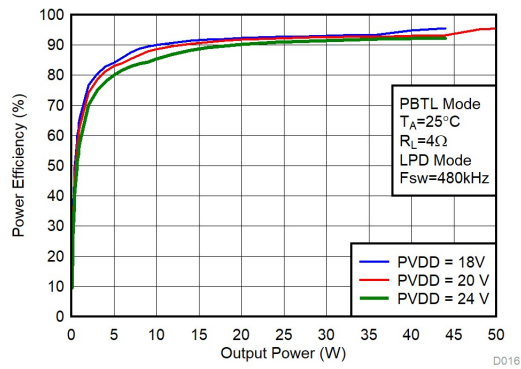

(Load=4Ω, Fsw=480kHz, LPD Mode)

Figure 22 Efficiency vs Output Power

Figure 21 Efficiency vs Output Power

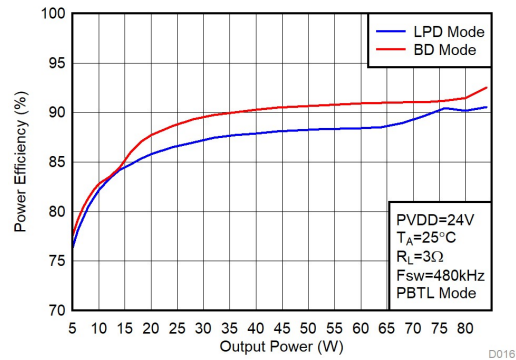

(Load=3Ω, Fsw=480kHz, HP vs LPD)

Figure 23 Efficiency vs Output Power

## 10. Detailed Description

### 10.1 Overview

The ACM8628 device integrates 4 main building blocks together into a single cohesive device that maximizes sound quality, flexibility, and ease of use. The 4 main building blocks are listed as follows:

- A stereo audio DAC
- An Audio Effect Tuning engine
- A flexible closed-loop amplifier capable of operating in stereo or mono, at different switching frequencies, and supporting a variety of output voltages and loads
- An I<sup>2</sup>C control port for communication with the device

The device requires only two power supplies for proper operation. A DVDD supply is required to power the low voltage digital circuitry. Another supply, called PVDD, is required to provide power to the output stage of the audio amplifier. Two internal LDOs convert PVDD to 5V for VREG\_AVDD and 1.8V for VREG\_DVDD respectively.

### 10.2 Functional Block Diagram

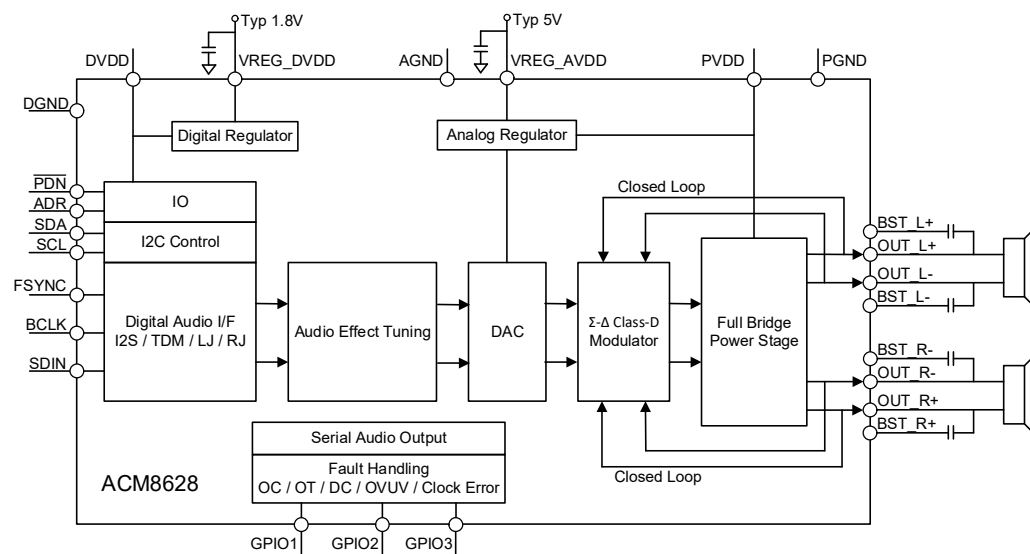

Figure 24 Function Block Diagram

## 10.3 Device Clocking

### 10.3.1 Main Clocks

The ACM8628 device has flexible systems for clocking. Internally, the device requires a few clocks, mostly at related clock rates to function correctly. All these clocks can be derived from the Serial Audio Interface.

The serial audio interface typically has 3 connection pins which are listed as follows:

- BCLK
- FSYNC/LRCLK (Left/Right Word Clock and Frame Sync)
- SDIN (Input Data)

The device has an internal PLL that is used to take BCLK as reference clock and create the higher rate clocks required by the Audio Effect Tuning and the DAC clock.

The ACM8628 device has an audio sampling rate detection circuit that automatically senses the sampling frequency. Common audio sampling frequencies of 32kHz, 44.1kHz-48kHz, 88.2kHz-96kHz, 176.4kHz-192kHz are supported. The sampling frequency detector sets the clock for DAC and Audio Effect Tuning automatically.

The ACM8628 device has an audio sampling rate detection circuit that automatically senses the sampling frequency. Common audio sampling frequencies of 32kHz, 44.1kHz-48kHz, 88.2kHz-96kHz, 176.4kHz-192kHz are supported. The sampling frequency detector sets the clock for DAC and Audio Effect Tuning automatically.

### 10.3.2 Serial Audio Port – Clock Rates

The serial audio interface port is a 3-wire serial port with the signals FSYNC/LRCLK, BCLK, and SDIN. BCLK is the serial audio bit clock, used to clock the serial data present on SDIN into the serial shift register of the audio interface. Serial data is clocked into the ACM8628 device on the rising edge of BCLK. The FSYNC/LRCLK pin is the serial audio left/right word clock or frame sync when the device is operated in TDM mode.

**Table 3. Audio Data Formats, Bit Depths and Clock Rates**

FORMAT	DATA BITS	MAXIMUM LRCLK/FS FREQUENCY (kHz)	BCLK RATE (Fs)
I <sup>2</sup> S/LJ/RJ	32,24,20,16	32 to 96	64,32
TDM	32,24,20,16	32	128
		44.1/48	128,256,512
		96	128,256

When clock halt, non-supported BCLK to FSYNC/LRCLK ratio is detected, the device reports clock error in Register 0x18 in Page0.

### 10.3.3 Clock Halt Auto-recovery

As some of host processor halts I<sup>2</sup>S clock when there is no audio playing. After clock halt, the device puts all channels into Hi-Z state and reports clock error in register 0x18 in Page0. After audio clock recovery, the device automatically returns to the previous state.

### 10.3.4 Sample Rate on The Fly Change

ACM8628 supports FSYNC/LRCLK rate on the fly change. For example, change FSYNC/LRCLK from 32kHz to 48kHz

or 96kHz, Host processor needs to put LRCLK (FSYNC) to Halt state at least 10ms before changing to new sample rate.

### 10.3.5 Serial Audio Port – Data Formats and Bit Depths

The device supports industry-standard audio data formats, including standard I<sup>2</sup>S, left-justified, right-justified and TDM/DSP data. Data formats are selected via Register 0x07 in Page0. If the high width of FSYNC/LRCLK in TDM/DSP mode is less than 8 cycles of BCLK, the register Page0/0x07 D[5:4] should be set to 01. All formats require binary two's complement, MSB-first audio data, up to 32-bit audio data is accepted. All the data formats, word length and clock rate supported by this device are shown in Table 1. The data formats are detailed in Figure 25 to Figure 29. The word length is selected via Register Page0/0x07 D[1:0]. The offset of data is selected via Register Page0/0x08.

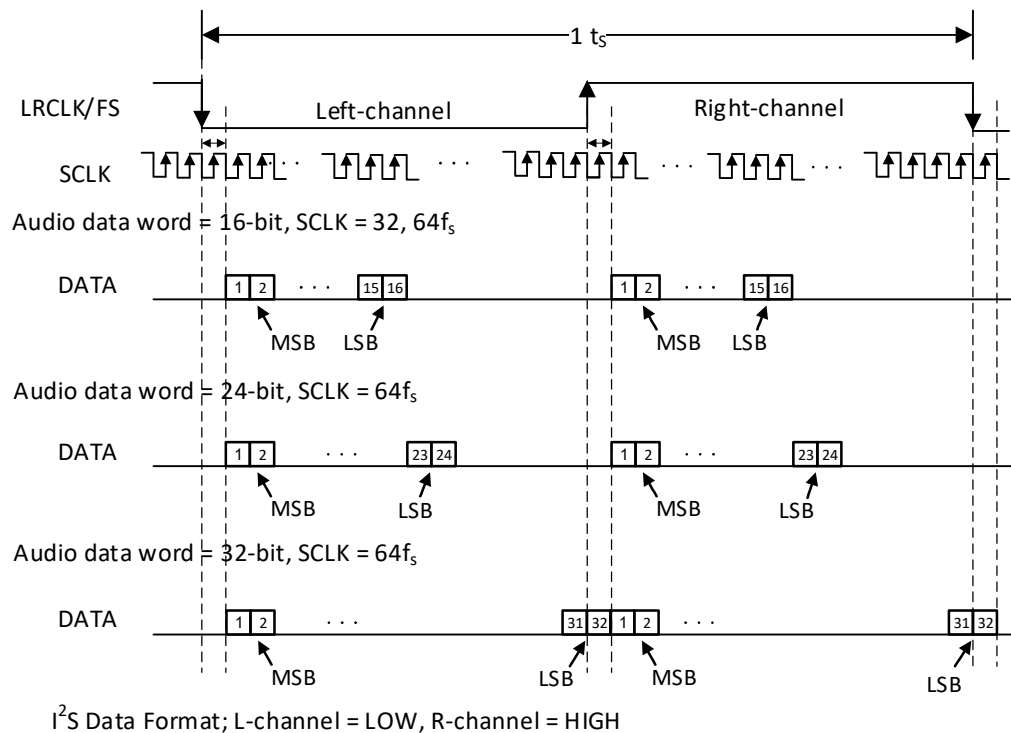

Figure 25 I<sup>2</sup>S Audio Data Format

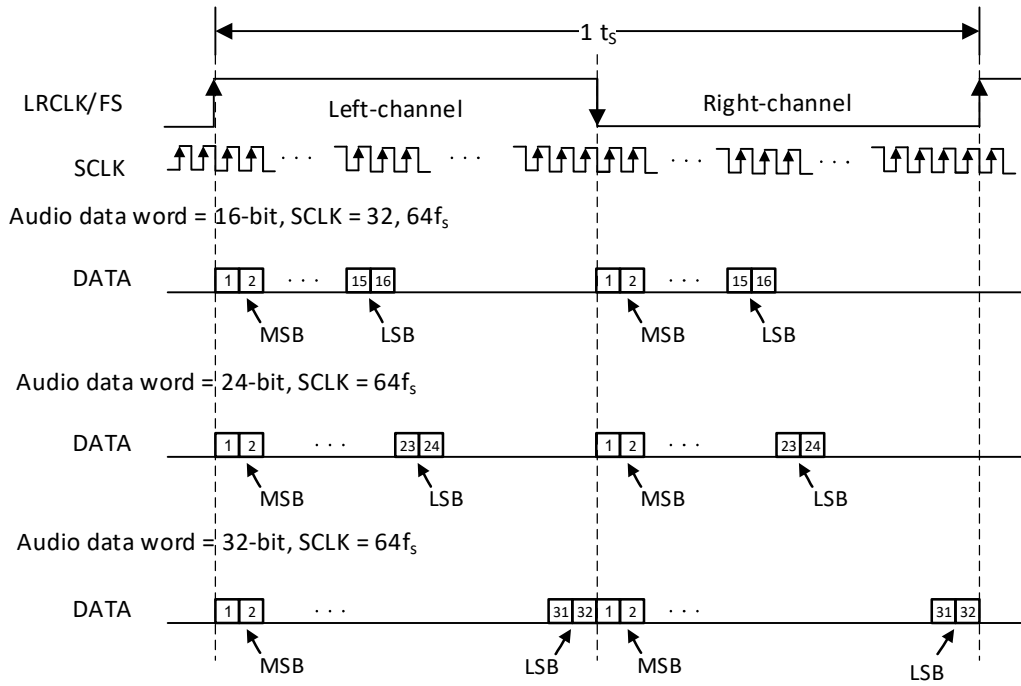

Figure 26 Left-Justified Audio Data Format

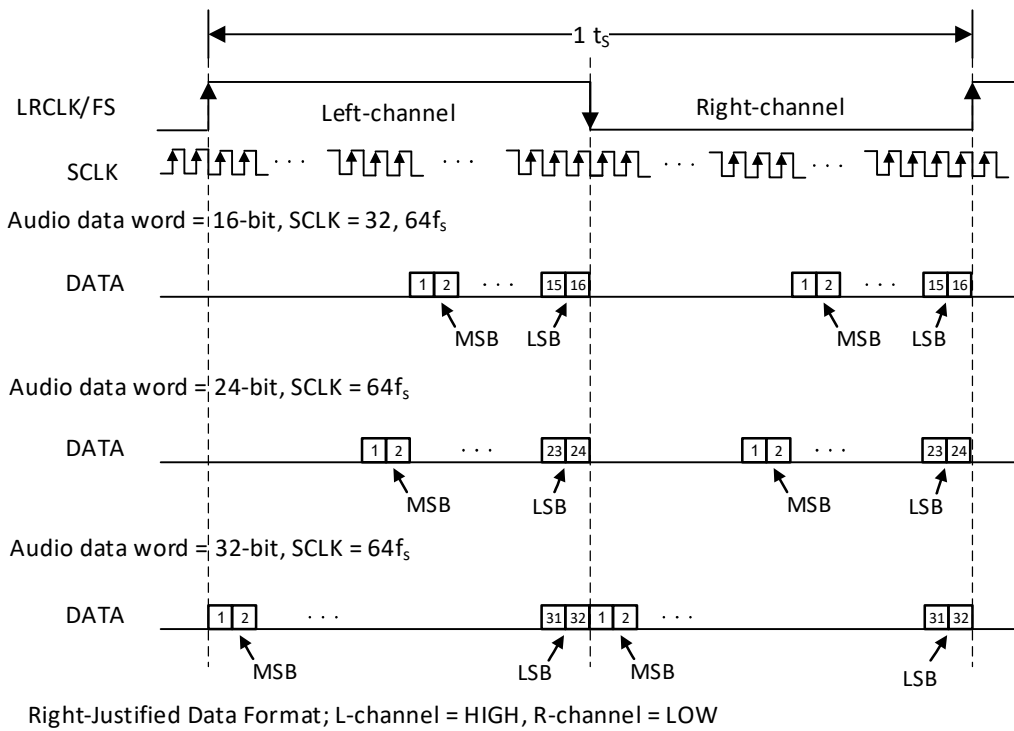
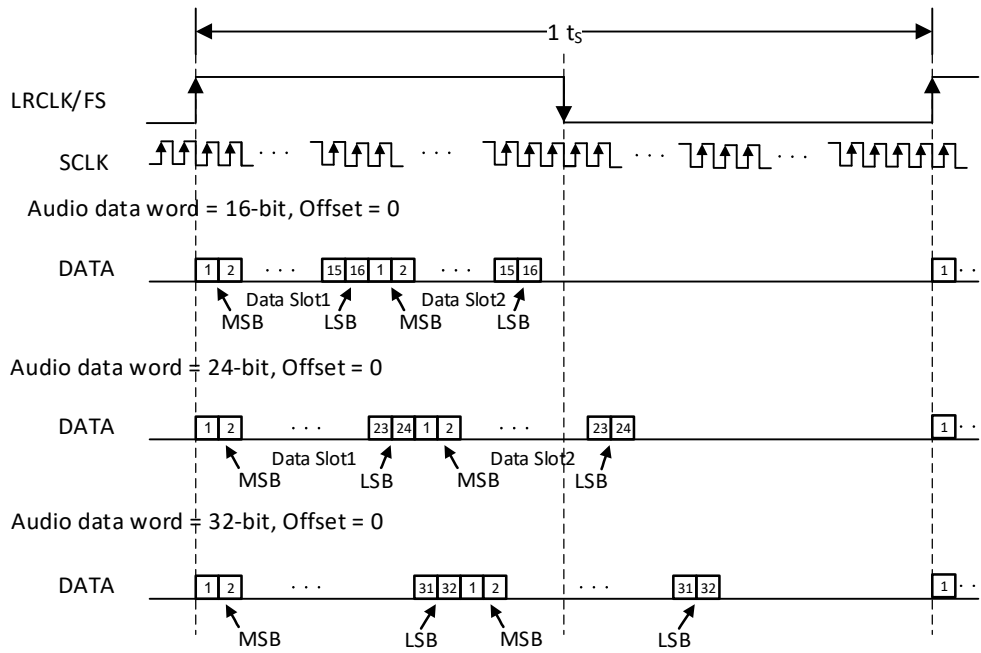

Figure 27 Right-Justified Audio Data Format



TDM Data Format with OFFSET = 0

In TDM Modes, Duty Cycle of LRCLK/FS should be  $1 \times$  SCLK at minimum. Rising edge is considered frame start

Figure 28 TDM 1 Audio Data Format

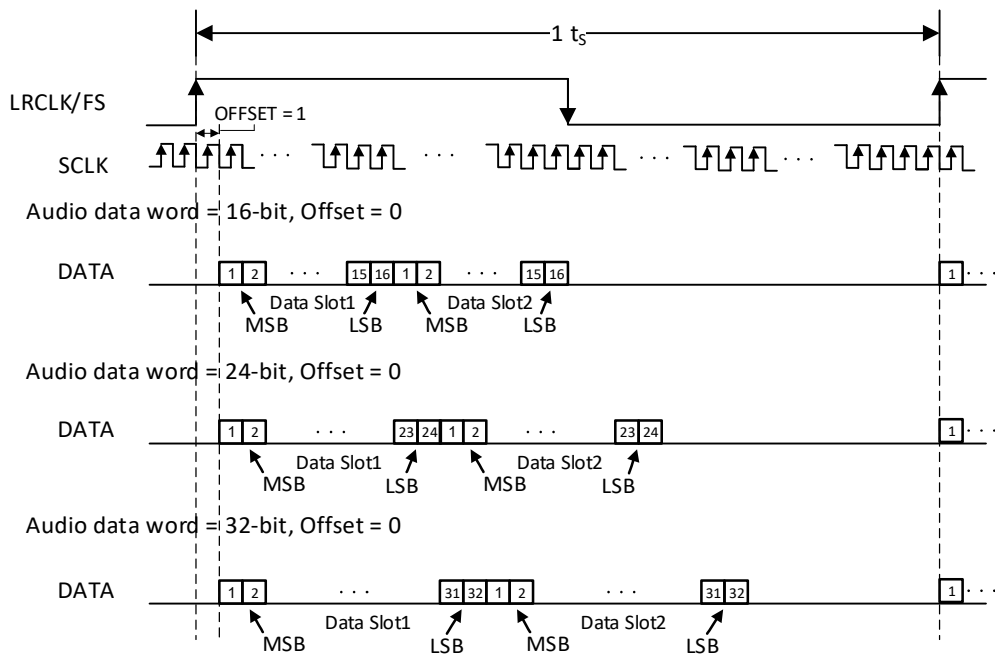

TDM Data Format with OFFSET = 1

In TDM Modes, Duty Cycle of LRCLK/FS should be  $1 \times$  SCLK at minimum. Rising edge is considered frame start

Figure 29 TDM 2 Audio Data Format

### 10.4 Power Supplies

To facilitate system design, ACM8628 needs only a 3.3-V supply in addition to (4.5V~26.4V) power-stage supply. Two internal voltage regulators provide suitable voltage levels for the gate drive circuitry and internal circuitry. The external pins are provided only as a connection point for off-chip bypass capacitors to filter the supply. Connecting

external circuitry to these regulators may result in reduced performance and damage to the device. Additionally, all circuitry requiring a floating voltage supply, e.g., the high-side gate drive, is accommodated by built-in bootstrap circuitry requiring only a few external capacitors. To provide good electrical and acoustical characteristics, the PWM signal path for the output stage is designed as identical, independent half-bridges. For this reason, each half-bridge has separate bootstrap pins (BST\_x). The gate drive voltages (VREG\_AVDD) are derived from the PVDD voltage. Special attention should be paid to placing all decoupling capacitors as close to their associated pins as possible. In general, inductance between the power-supply pins and decoupling capacitors must be avoided. For a properly functioning bootstrap circuit, a small ceramic capacitor must be connected from each bootstrap pin (BST\_x) to the power-stage output pin (OUT\_x). When the power-stage output is low, the bootstrap capacitor is charged through an internal diode connected between the gate-drive regulator output pin (VREG\_AVDD) and the bootstrap pin. When the power-stage output is high, the bootstrap capacitor potential is shifted above the output potential and thus provides a suitable voltage supply for the high-side gate driver.

## 10.5 Device Gain Setting

As seen in the figure below, the audio path of the ACM8628 consists of a digital audio input port, a digital audio path, a digital to PWM convertor, a gate driver stage, a Class D power stage, and the feedback loop which feeds the output information back into the digital to PWM block to correct for distortion sensed on the output pins. The total amplifier gain is comprised of digital gain in the digital audio path and the analog gain from the input of the analog modulator to the output of the speaker amplifier power stage.

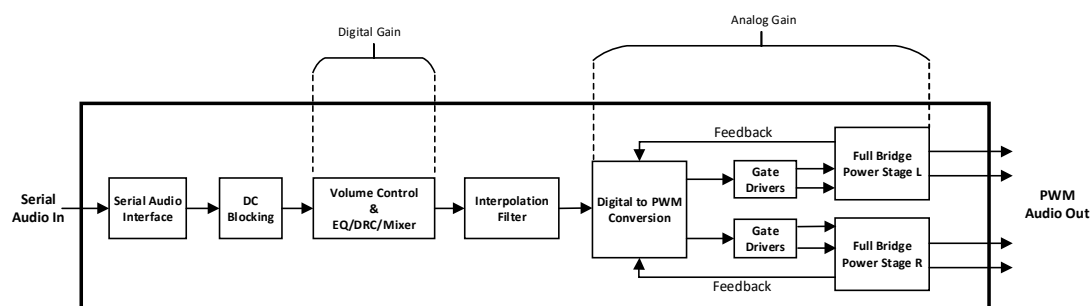

Figure 30 Gain Structure

As shown above, the first gain stage for the speaker amplifier is present in the digital audio path. It consists of the volume control and EQ/DRC/Mixer. The volume control is set to 0dB by default and EQ/DRC/Mixer is bypassed by default.

Amplifier analog gain settings are presented as the output level in dBV (dB related to 1V<sub>rms</sub>) with a full-scale serial audio input (0dBFS) and the digital volume control set to 0dB.

$$V_{AMP} = \text{Input} + \text{Digital Gain} + \text{Analog Gain dBV}$$

Where:

- $V_{AMP}$  is the amplifier output voltage in dBV<sub>RMS</sub>
- Input is the digital input amplitude in dB with respect to 0dBFS
- Digital Gain is the digital volume control setting, -110dB to 24dB.
- Analog Gain is the analog gain setting (26.38, 25.88, 25.38 to 10.88 dBV<sub>RMS</sub> in 0.5dB step)

Table 2 outlines gain setting expressed in dBV<sub>RMS</sub> and V<sub>PEAK</sub>.

Table 4 Amplifier Gain Settings

Analog Gain (Register 0x02h in Page0)	FULL SCALE OUTPUT	
	dBV <sub>RMS</sub>	V <sub>PEAK</sub>
00000	26.38	29.5

00001	25.88	27.84
00010	25.38	26.3
00011	24.88	24.8
...	...	...
01110	19.38	13.17
01111	18.88	12.44
10000	18.38	11.74
...	...	...
11111	10.88	4.95

## 10.6 Device Protection

ACM8628 has built-in protection circuits including thermal, short-circuit, under-voltage detection, over-voltage detection, output DC detection, clock error detection circuits. Once these faults occur, ACM8628 reports fault via register 0x17h-0x19h in Page0 and these faults may pull the GPIO1/2 pin to DGND by proper setting in Register 0x0Ah and 0x0Ch in Page0. Clear these faults by writing Bit7 in register 0x01h in Page0 from 0 to 1.

1. Over temperature protection. When the internal junction temperature is higher than 160°C power stages will be turned off and ACM8628 will return to normal operating once the temperature drops to 150°C. The temperature values may vary around 10%. Enable Over temperature protection auto-recovery by writing Register 0x11h (Bit 2) from 0 to 1.
2. Short-circuit protection. The short-circuit protection protects the output stage when the wires connect to loudspeakers are shorted to each other or GND/PVDD. For normal 24V operations, the current flowing through the power stage will be less than 7.5A for stereo configuration. Otherwise, the short-circuit detectors pull the  $\overline{\text{FAULT}}$  pin (GPIO pin) to DGND, disabling the output stages.
3. PVDD over-voltage protection. Once the PVDD voltage is higher than 28V, ACM8628 turns off its loudspeaker power stages. When PVDD becomes lower than 27.5V, ACM8628 will return to normal operation.
4. PVDD under-voltage protection. Once the PVDD voltage is lower than 4V, ACM8628 turns off its loudspeaker power stages. When PVDD becomes higher than 4.3V, ACM8628 will return to normal operation.
5. Speaker DC Protection. Once the output differential voltage exceeds 1.9V (typical) for more than 570ms (typical) at the same polarity. ACM8628 will turn off its loudspeaker stages. Once this fault been removed, clear this fault by writing Bit7 in register 0x01h from 0 to 1 or device will keep output stages in Hi-Z state.
6. Clock error protection. When clock halt, non-supported BCLK to FSYNC/LRCLK ratio is detected, the device reports clock error in Register 0x18 in Page0. Once the fault been removed, device will return to normal operation.

## 10.7 Class H Control

ACM86xx Class-H Control provides a new scheme to increase efficiency and reduce power dissipation for battery supply system. ACM86xx internal Class H block monitors the digital audio signal and provides control signal to feedback network of external DC-DC Boost Convertor, adjust Boost Convertor's  $V_{\text{OUT}}$  accordingly. As ACM86xx use the external Booster Convertor's  $V_{\text{OUT}}$  as the power supply, so ACM86xx's Power supply dynamic tracking with output audio signal, shown in Figure 31.

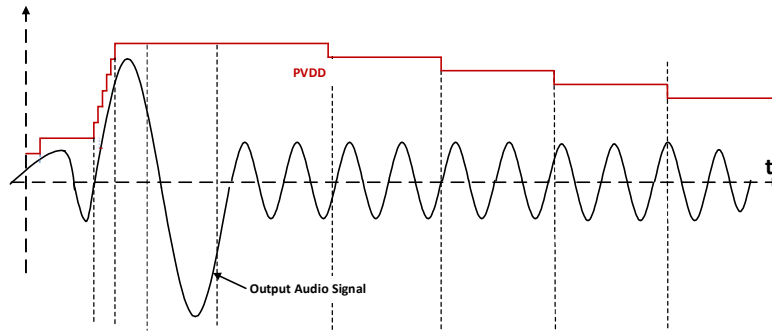
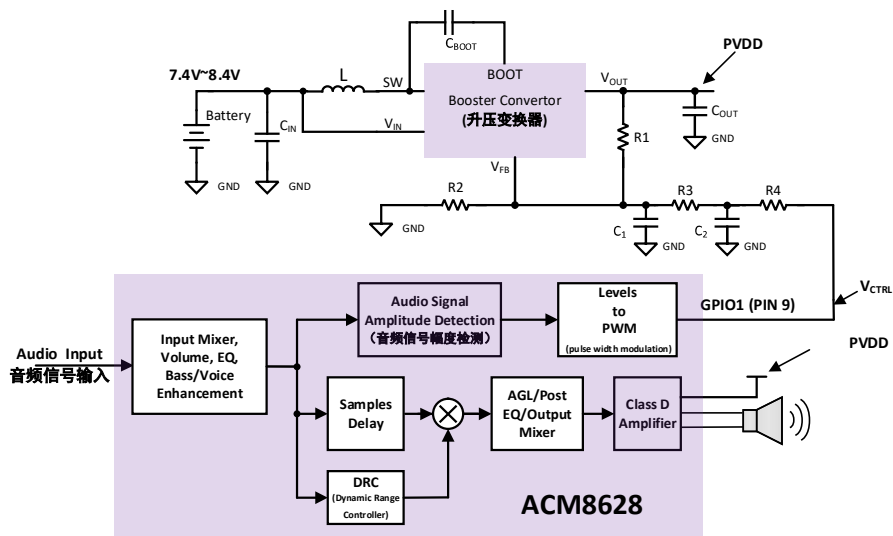

Figure 31 Class H Operation Signal

ACM86xx employ an internal Audio Signal Amplitude Detection Block for audio signal amplitude detection, as the target PVDD range and the amplifier system gain is known, so the digital input levels in 'Levels to PWM' block will calculate the proper digital input levels and transfers to different duty cycle. Generally, ACM86xx supports 16 levels Class H Control. For example, if the PVDD range is 9V-16V, the PVDD tracking with output audio signals by following values: { 9V, 9.466V, 9.933V, 10.399V, 10.866V, 11.333V, 11.799V, 12.266V, 12.732V, 13.199V, 14.132V, 14.599V, 15.065V, 15.532V, 15.999V }.

Based on detailed system application requirement (PVDD min/max value,  $V_{FB}$  of the Booster Converter, DVDD value,  $R_2$ ), ACME Audio Tuning software generates corresponding register configuration and external BOM which shown in Figure 32.



$$\frac{V_{OUT}-V_{FB}}{R_1} = \frac{V_{FB}}{R_2} + \frac{V_{FB}-V_{CTRL}}{R_3+R_4}$$

Figure 32 Class H Control Block

## 10.8 Spread Spectrum

ACM8628 supports spread spectrum with triangle mode. Spread spectrum is used to minimize the EMI noise.

Enable spread spectrum in register 0x0Eh in Page 0, default is disable.

Enable Spread Spectrum Script with following sequence (Suitable for 384kHz/480kHz/576kHz switching frequency):

1. Step1, Write content 0x00 to Register address 0x00.
2. Step2, Write content 0x01 to Register address 0x0E.
3. Step3, Write content 0x01 to Register address 0x00.

4. Step4, Write content 0x0b to Register address 0x1A.
5. Step5, Write content 0x00 to Register address 0x00.

## 10.9 I<sup>2</sup>C Device Address

The ACM8628 device has 7 bits for I<sup>2</sup>C device address. The first five bits (MSBs) of the device address are factory preset to 00101 (0x2x). The next two bits of address byte are the device select bits which can be user-defined by ADR pin in Table 5.

Table 5 I<sup>2</sup>C Device Address Configuration

ADR PIN Configuration	MSBs					User Define		LSB	Device Write Address
	0	0	1	0	1	0	0		
4.7kΩ to DVDD	0	0	1	0	1	0	0	R/W	0x28
15kΩ to DVDD	0	0	1	0	1	0	1	R/W	0x2a
47kΩ to DVDD	0	0	1	0	1	1	0	R/W	0x2c
120kΩ to DVDD	0	0	1	0	1	1	1	R/W	0x2e

## 10.10 Start-up sequence

1. Configure ADR/GPIO2 pin with proper setting for I<sup>2</sup>C device address.
2. Bring up power supplies.
3. Once all power supplies are stable, bring up the PDN pin HIGH 1ms before I<sup>2</sup>C communication.
4. Configure the device via I<sup>2</sup>C control port based on the user case (Make sure the PDN pin= HIGH before I<sup>2</sup>C control port operating).
5. The device is now in normal operation.

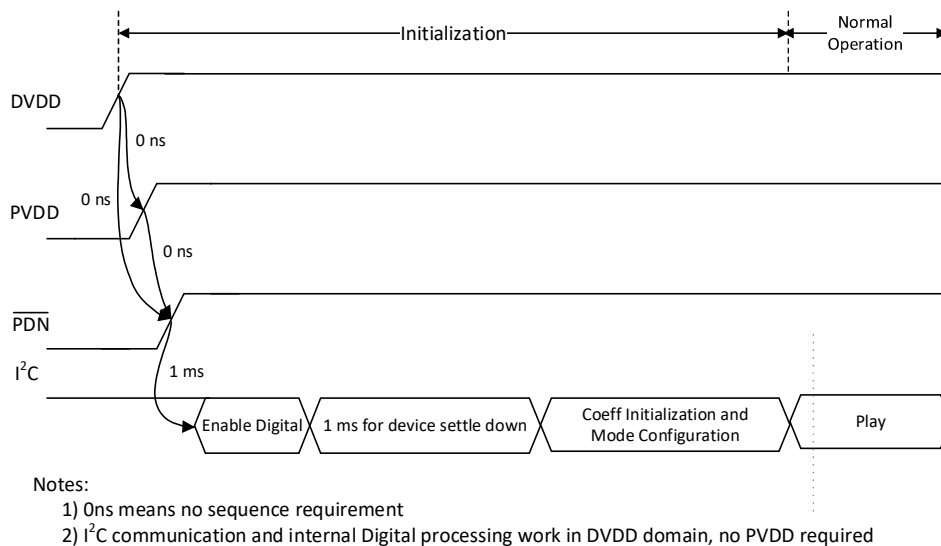
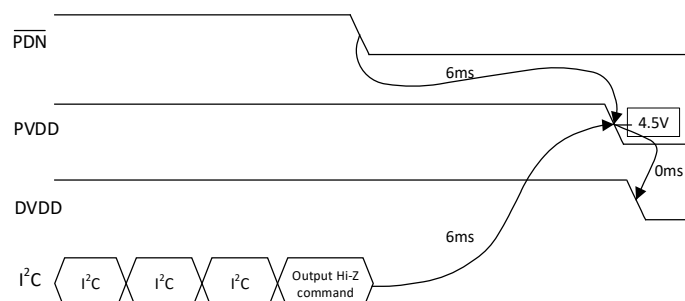

Figure 33 Start-up Sequence

## 10.11 Shutdown sequence

1. The device is in normal operation.
2. Configure the device in digital off state via register 0x04h or pull PDN low.
3. Wait at least 6ms (This time depends on the FSYNC rate, digital volume and digital volume ramp down rate).
4. Bring down power supplies.
5. The device is now fully shutdown and powered off.



- Before PVDD/DVDD power down, Class D Output driver needs to be disabled by  $\overline{\text{PDN}}$  or by I<sup>2</sup>C.
- At least 6ms delay needed based on LRCLK (Fs) = 48kHz, Digital volume ramp down update every sample period, decreased by 0.5dB for each update, digital volume = 24dB.

Figure 34 Shutdown Sequence

### 11. Application Circuit Example of Stereo

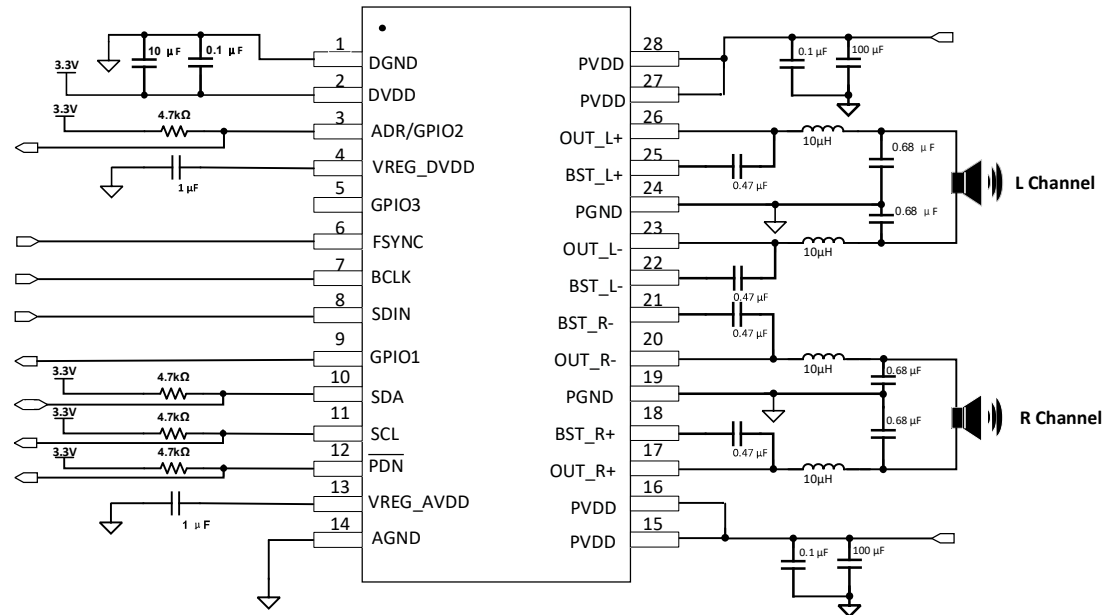

### 12. Application Circuit Example of Mono

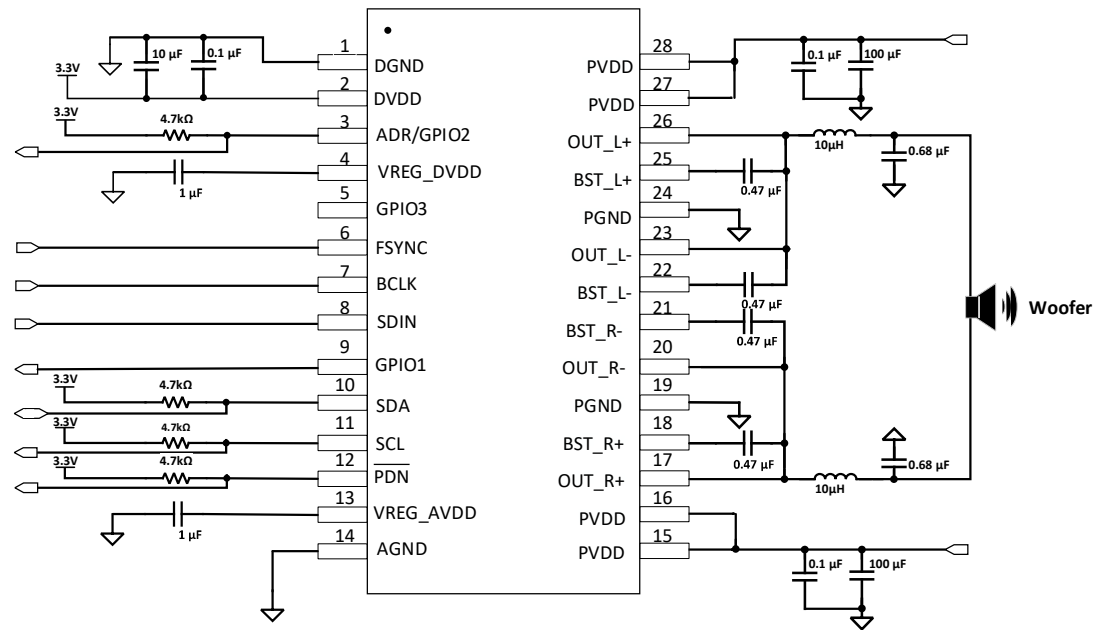

## 13. Register Maps

### 13.1 Control Registers on Page0

Offset	Acronym	Register Name	Reset Value
0x01	AMP_CTRL1	F <sub>sw</sub> PWM switching frequency, Fault clear, PBTL/BTL	0x00
0x02	AMP_CTRL2	Analog gain	0x00
0x03	AMP_CTRL3	Loop bandwidth, 2 PWM channels phase control	0x00
0x04	STATE_CTRL	Reset, Separate channel Hi-Z / Mute, State Control	0x00
0x05	PROCESSING_CTRL1	AGL, DRB, Post EQ, Sub-CH bypass control	0x12
0x06	PROCESSING_CTRL2	Processing flow selection and low power mode selection	0xF0
0x07	I2S_DATA_FORMAT1	I2S data format, length, FSYNC	0x02
0x08	I2S_DATA_FORMAT2	I2S Shift bits	0x00
0x09	I2S_DATA_FORMAT3	Reserved	0x05
0x0A	GPIO2_CTRL	SDOUT (GPIO2) enable and function selection	0x29
0x0B	GPIO1_CTRL	ADR (GPIO1) enable and function selection	0x2B
0x0C	GPIO1_FAULT_SEL	Clipping, OTW, OTSD, Clock Fault, PVDD UV/OV, DC, OC selection	0xFF
0x0D	GPIO2_FAULT_SEL	Clipping, OTW, OTSD, Clock Fault, PVDD UV/OV, DC, OC selection	0xFF
0x0E	SS_CTRL	Spread spectrum setting	0x00
0x0F	VOLUME_CTRL_L	Volume control for left channel	0xD0
0x10	VOLUME_CTRL_R	Volume control for right channel	0xD0
0x11	MSIC_CTRL	Fault latch selection, OTSD auto-recovery enable	0x03
0x12	I2S_CLK_FORMAT_RPT1	BCLK ratio (MSB), Sample rate detect	0x00
0x13	I2S_CLK_FORMAT_RPT2	BCLK ratio (LSB)	0x00
0x15	DIEID_RPT	DIE ID	0x00
0x16	STATE_RPT	State report	0x00
0x17	FAULT_RPT1	OTSD, PVDD OV/UV, DC, OC	0x00
0x18	FAULT_RPT2	Clock fault, EQs write error	0x00
0x19	FAULT_RPT3	Clipping, OTW	0x00
0x7E	XOR_CHECKSUM	XOR Checksum	0x00
0x7F	CRC_CHECKSUM	CRC Checksum	0x00

#### 13.1.1 Register 1 AMP\_CTRL1 (Offset=1h) [Reset=0x00]

7	6	5	4	3	2	1	0
FAULT_CLR	RESERVED			FSW_SWL			PBTL
R/W	R			R/W			R/W

Bit	Field	Type	Reset	Description
7	FAULT_CLR	R/W	0	Once write this bit to 1, device will clear analog fault, this bit is auto-clear

6-4	RESERVED	R	000	These bits are reserved
3-1	FSW_SEL	R/W	000	000: 384kHz 001: Reserved 010: 480kHz 011: 576kHz 100: 768kHz
0	PBTL	R/W	0	0: BTL Mode 1: PBTL Mode, PBTL can be set when device is in digital off state

### 13.1.2 Register 2 AMP\_CTRL2 (Offset=2h) [Reset=0x00]

7	6	5	4	3	2	1	0
RESERVED			ANA_GAIN				
R			R/W				

Bit	Field	Type	Reset	Description
7-5	RESERVED	R	000	These bits are reserved
4-0	ANA_GAIN	R/W	00000	Analog Gain Control, with 0.5dB per step. These bits control the analog gain. 00000: 0dB (29.5Vp/FS) 00001: -0.5dB 00010: -1dB ... 11111: -15.5dB

### 13.1.3 Register 3 AMP\_CTRL3 (Offset=3h) [Reset=0x00]

7	6	5	4	3	2	1	0
RESERVED		CH_PHASE_CTL	RESERVED		BW_CTRL		
R		R/W	R		R/W		

Bit	Field	Type	Reset	Description
7-6	RESERVED	R	00	These bits are reserved
5	CH_PHASE_CTRL	R/W	0	0: out phase 1: in phase
2-0	BW_CTRL	R/W	000	000: 75kHz 001: 90kHz 010: 105kHz 011: 125kHz 100: 155kHz 101: 180kHz 110: 220kHz 111: 265kHz

**13.1.4 Register 4 STATE\_CTRL (Offset=4h) [Reset=0x00]**

7	6	5	4	3	2	1	0
RST_REG	REST_MOD	CH_L_HIZ	CH_R_HIZ	MUTE_L	MUTE_R	CTRL_STATE	
R/W	R/W	R/W	R/W	R/W	R/W	R/W	

Bit	Field	Type	Reset	Description
7	RST_REG	R/W	0	Register Reset 0: Normal 1: Reset Register
6	RST_MOD	R/W	0	Signal path Reset 0: Normal 1: Reset Signal path
5	CH_L_HIZ	R/W	0	Force Channel L's output driver into Hi-Z state 0: Normal State 1: Change L channel's output driver into Hi-Z state
4	CH_R_HIZ	R/W	0	Force Channel R's output driver into Hi-Z state 0: Normal State 1: Change R channel's output driver into Hi-Z state
3	MUTE_L	R/W	0	MUTE L Channel 0: Normal 1: Mute L Channel
2	MUTE_R	R/W	0	MUTE R Channel 0: Normal 1: Mute R Channel
1-0	CTRL_STATE	R/W	00	00: Digital Off 01: Analog off 10: Driver Off (Hiz) 11: Play

**13.1.5 Register 5 PROCESSING\_CTRL1 (Offset=5h) [Reset=0x12]**

7	6	5	4	3	2	1	0
AGL_BP	DRB_BP	RESERVED		POST_EQ_BP	RESERVED	SUB_CH_BP	PROCESSING_BP
R/W	R/W	R		R/W	R	R/W	R/W

Bit	Field	Type	Reset	Description
7	AGL_BP	R/W	0	0: Enable AGL 1: Bypass AGL
6	DRB_BP	R/W	0	0: Enable DRB 1: Bypass DRB
5-4	RESERVED	R	0	These bits are reserved

Bit	Field	Type	Reset	Description
3	POST_EQ_BP	R/W	0	0: Enable Post-EQ 1: Bypass Post-EQ
2	RESREVED	R	0	This bit is reserved
1	SUB_CH_BP	R/W	1	0: Enable Sub Channel Processing 1: Bypass Sub Channel Processing
0	PROCESSING_BP	R/W	0	0: Enable audio effect tuning 1: Bypass all audio effect tuning

### 13.1.6 Register 6 PROCESSING\_CTRL2 (Offset=6h) [Reset=0xF0]

7	6	5	4	3	2	1	0
RESERVED				POWER_SAVE_DOWN	PLL_CLK_DIV		REAL_96KHZ
R				R/W	R/W		R/W

Bit	Field	Type	Reset	Description
7-4	RESERVED	R	1111	These bits are reserved
3	POWER_SAVE_DOWN	R/W	0	0: when have clock fault, device will not shut down analog and digital, only shut down driver 1: when have clock fault, device will shut down analog and digital and driver
2-1	PLL_CLK_DIV	R/W	0	00: high PLL frequency 01: middle PLL frequency 10: low PLL frequency 11: low PLL frequency
0	REAL_96KHZ	R/W	0	0: 48kHz internal processing 1: 96kHz internal processing

### 13.1.7 Register 7 I2S\_DATA\_FORMAT1 (Offset=7h) [Reset=0x02]

7	6	5	4	3	2	1	0
44K_INPUT	44K_EN	I2S_DATA_FORMAT1		I2S_FSYNC_PULSE		I2S_WORD_LENGTH	
R/W	R/W	R/W		R/W		R/W	

Bit	Field	Type	Reset	Description
7	44K_INPUT	R/W	0	0: 48K/96K/192K input 1: 44.1K/88.2K/176.4K input
6	44K_EN	R/W	0	0: disable 44k input 1: enable 44k input
5-4	I2S_DATA_FORMAT	R/W	00	00: I2S 01: TDM/DSP 10: RTJ 11: LTJ

Bit	Field	Type	Reset	Description
3-2	I2S_FSYNC_PULSE	R/W	00	01: FSYNC pulse <8 BCLK. If the high width of LRCLK/FSYNC in TDM/DSP mode is less than 8 cycles of BCLK, these two bits need set to 01. Others: These bits are reserved
1-0	I2S_WORD_LENGTH	R/W	10	I2S Word length. These bits control both input and output audio interface sample word lengths for DAC operation. 00: 16 bits 01: 20 bits 10: 24 bits 11: 32 bits

### 13.1.8 Register 8 I2S\_DATA\_FORMAT2 (Offset=8h) [Reset=0x00]

7	6	5	4	3	2	1	0
I2S_LEFT_BITS_SHIFT							
R/W							

Bit	Field	Type	Reset	Description
7-0	I2S_LEFT_BIT_SHIFT	R/W	00000000	Control the offset of Left Channel audio data in the audio frame for both input and output. The offset is defined as the number of BCLK from the starting (MSB) of audio frame to the starting of the desired audio sample. 00000000: offset = 0 BCLK (no offset) 00000001: offset = 1 BCLK ..... 11111111: offset = 256 BCLK

### 13.1.9 Register 9 I2S\_DATA\_FORMAT3 (Offset=9h) [Reset=0x00]

7	6	5	4	3	2	1	0
RESERVED							
R							

Bit	Field	Type	Reset	Description
7-0	RESERVED	R	00000000	These bits are reserved.

**13.1.10 Register 10 GPIO1\_CTRL (Offset=0Ah) [Reset=0x29]**

7	6	5	4	3	2	1	0
RESERVED		GPIO1_OE	GPIO1_FUNC_SEL				
R		R/W	R/W				

Bit	Field	Type	Reset	Description
7-6	RESERVED	R	00	These bits are reserved
5	GPIO1_OE	R/W	1	0: GPIO1 is input 1: GPIO1 is output
4-0	GPIO1_FUNC_SEL	R/W	01001	DEFAULT is SDOUT 0000: off(low) 0001: digital off 0010: analog off 0011: driver off 0100: mute right 0101: mute left 0110: clock invalid flag(clock error or clock missing) 0111: pll lock flag 1000: GPIO1 as WARNZ output 1001: serial audio interface data output(SDOUT) 1011: GPIO1 as FAULTZ output 1100: resetz

**13.1.11 Register 11 GPIO2\_CTRL (Offset=0Bh) [Reset=0x2B]**

7	6	5	4	3	2	1	0
RESERVED		GPIO2_OE	GPIO1_FUNC_SEL				
R		R/W	R/W				

Bit	Field	Type	Reset	Description
7-6	RESERVED	R	00	These bits are reserved
5	GPIO2_OE	R/W	1	0: GPIO2 is input 1: GPIO2 is output
4-0	GPIO2_FUNC_SEL	R/W	01011	DEFAULT is FAULT pin 0000: off(low) 0001: digital off 0010: analog off 0011: driver off 0100: mute right 0101: mute left 0110: clock invalid flag(clock error or clock missing) 0111: pll lock flag

Bit	Field	Type	Reset	Description
				1000: gpio1 as WARNZ output 1001: serial audio interface data output(SDOUT) 1011: GPIO2 as FAULTZ output 1100: resetz

### 13.1.12 Register 12 GPIO1\_FAULT\_SEL (Offset=0Ch) [Reset=0xFF]

7	6	5	4	3	2	1	0
CLIP	OTW	OTSD	CLK_FAULT	PVDD_UV	PVDD_OV	DC	OC
R/W	R/W	R/W	R/W	R/W	R/W	R/W	R/W

Bit	Field	Type	Reset	Description
7	CLIP	R/W	1	0: Mask; 1: Report
6	OTW	R/W	1	0: Mask; 1: Report
5	OTSD	R/W	1	0: Mask; 1: Report
4	CLK_FAULT	R/W	1	0: Mask; 1: Report
3	PVDD_UV	R/W	1	0: Mask; 1: Report
2	PVDD_OV	R/W	1	0: Mask; 1: Report
1	DC	R/W	1	0: Mask; 1: Report
0	OC	R/W	1	0: Mask; 1: Report

### 13.1.13 Register 13 GPIO2\_FAULT\_SEL (Offset=0Dh) [Reset=0xFF]

7	6	5	4	3	2	1	0
CLIP	OTW	OTSD	CLK_FAULT	PVDD_UV	PVDD_OV	DC	OC
R/W	R/W	R/W	R/W	R/W	R/W	R/W	R/W

Bit	Field	Type	Reset	Description
7	CLIP	R/W	1	0: Mask; 1: Report
6	OTW	R/W	1	0: Mask; 1: Report
5	OTSD	R/W	1	0: Mask; 1: Report
4	CLK_FAULT	R/W	1	0: Mask; 1: Report
3	PVDD_UV	R/W	1	0: Mask; 1: Report
2	PVDD_OV	R/W	1	0: Mask; 1: Report
1	DC	R/W	1	0: Mask; 1: Report
0	OC	R/W	1	0: Mask; 1: Report

**13.1.14 Register 14 SS\_CTRL (Offset=0Eh) [Reset=0x00]**

7	6	5	4	3	2	1	0
RESERVED						RDM_EN	TRI_EN
R						R/W	R/W

Bit	Field	Type	Reset	Description
7-2	RESERVED	R	00000	These bits are reserved
1	RDM_EN	R/W	0	0: Random SS disable 1: Random SS enable
0	TRI_EN	R/W	0	0: Triangle SS disable 1: Triangle SS enable

**13.1.15 Register 15 VOLUME\_CTRL\_L (Offset=0Fh) [Reset=0xD0]**

7	6	5	4	3	2	1	0
VOL_L							
R/W							

Bit	Field	Type	Reset	Description
7-0	VOL_L	R/W	11010000	Volume control for left channel. 00000000: -104dB .... 11010000: 0dB 11010001: 0.5dB .... 11111111: 24dB

**13.1.16 Register 16 VOLUME\_CTRL\_R (Offset=10h) [Reset=0xD0]**

7	6	5	4	3	2	1	0
VOL_R							
R/W							

Bit	Field	Type	Reset	Description
7-0	VOL_R	R/W	11010000	Volume control for right channel. 00000000: -104dB .... 11010000: 0dB 11010001: 0.5dB .... 11111111: 24dB

**13.1.17 Register 17 MISC\_CTRL (Offset=11h) [Reset=0xA3]**

7	6	5	4	3	2	1	0
RESERVED					OTSD_AUTO_REC	GPIO2_FAULT_LATCH	GPIO1_FAULT_LATCH
R					R/W	R/W	R/W

Bit	Field	Type	Reset	Description
7-6	RESERVED	R	10	These bits are reserved
5		R/W	1	0: Disable CBC 1: Enable CBC
2	OTSD_AUTO_REC	R/W	0	0: OT auto-recovery disable 1: OT auto-recovery enable
1	GPIO2_FAULT_LATCH	R/W	1	0: GPIO2 report fault not latched 1: GPIO2 report fault latched
0	GPIO1_FAULT_LATCH	R/W	1	0: GPIO1 report fault not latched 1: GPIO1 report fault latched

**13.1.18 Register 18 I2S\_CLK\_FORMAT\_RPT1 (Offset=12h) [Reset=0x00]**

7	6	5	4	3	2	1	0
RESERVED		BCLK_RATIO_HIGH		FS_DET			
R		R		R			

Bit	Field	Type	Reset	Description
7-6	RESERVED	R	00	These bits are reserved
5-4	BCLK_RATIO_HIGH	R	00	These bits indicate the BCLK ratio, the number of BCLK in one audio frame. BCLK=32FS-512FS MSB Bit [9-8].
3-0	FS_DET	R	0000	These bits indicate the currently detected audio sample rate. 0110: 32KHZ 1000: 44.1KHZ 1001: 48KHZ 1010: 88.2KHZ 1011: 96KHZ 1100: 176.4KHZ 1101: 192KHZ

**13.1.19 Register 19 I2S\_CLK\_FORMAT\_RPT2 (Offset=13h) [Reset=0x00]**

7	6	5	4	3	2	1	0
BCLK_RATIO							
R							

Bit	Field	Type	Reset	Description
7-0	BCLK_RATIO	R	00000000	These bits indicate the BCLK ratio, the number of BCLK in one audio frame. 00000000: 00000001: ... 11111111:

**13.1.20 Register 20 DIEID\_RPT (Offset=15h) [Reset=0x00]**

7	6	5	4	3	2	1	0
DIEID_RPT							
R							

Bit	Field	Type	Reset	Description
7-0	DIE_ID	R	00000000	DIE ID

**13.1.21 Register 21 STATE\_RPT (Offset=16h) [Reset=0x00]**

7	6	5	4	3	2	1	0
RESERVED						STATE_RPT	
R						R	

Bit	Field	Type	Reset	Description
7-2	RESERVED	R	000000	These bits are reserved
1-0	STATE_RPT	R	00	00: Digital Off 01: Analog Off 10: Driver Off (Hiz) 11: Play

**13.1.22 Register 22 FAULT\_RPT1(Offset=17h) [Reset=0x00]**

7	6	5	4	3	2	1	0
RESERVED	OTSD	PVDD_OV	PVDD_UV	CH2_DC	CH1_DC	CH2_OC	CH1_OC
R	R	R	R	R	R	R	R

Bit	Field	Type	Reset	Description
7	RESERVED	R	0	This bit is reserved
6	OTSD	R	0	0: Normal 1: Over temperature shutdown fault report
5	PVDD_OV	R	0	0: Normal 1: PVDD over-voltage fault report
4	PVDD_UV	R	0	0: Normal 1: PVDD under-voltage fault report
3	CH2_DC	R	0	0: Normal 1: CH2 speaker DC fault report
2	CH1_DC	R	0	0: Normal 1: CH1 speaker DC fault report
1	CH2_OC	R	0	0: Normal 1: CH2 over-current fault report
0	CH1_OC	R	0	0: Normal 1: CH1 over-current fault report

**13.1.23 Register 23 FAULT\_RPT2(Offset=18h) [Reset=0x00]**

7	6	5	4	3	2	1	0
RESERVED					CLK_FAULT	RESERVED	
R					R	R	

Bit	Field	Type	Reset	Description
7-3	RESERVED	R	00000	These bits are reserved
2	CLK_FAULT	R	0	0: Normal 1: Clock fault report
1-0	RESERVED	R	0	These bits are reserved

**13.1.24 Register 24 FAULT\_RPT3(Offset=19h) [Reset=0x00]**

7	6	5	4	3	2	1	0
RESERVED					CH2_CLIP	CH1_CLIP	OTW
R					R	R	R

Bit	Field	Type	Reset	Description
7-3	RESERVED	R	00000	These bits are reserved
2	CH2_CLIP	R	0	0: Normal 1: Channel 2 clipping
1	CH1_CLIP	R	0	0: Normal 1: Channel 1 clipping
0	OTW	R	0	0: Normal 1: Over temperature warning

**13.1.25 Register 25 XOR\_CHECKSUM(Offset=7Eh) [Reset=0x00]**

7	6	5	4	3	2	1	0
XOR_CHECKSUM							
R							

Bit	Field	Type	Reset	Description
7-0	XOR_CHECKSUM	R	0	XOR checksum result

**13.1.26 Register 26 CRC\_CHECKSUM(Offset=7Fh) [Reset=0x00]**

7	6	5	4	3	2	1	0
CRC_CHECKSUM							
R							

Bit	Field	Type	Reset	Description
7-0	CRC_CHECKSUM	R	0	CRC checksum result

## 14. Package Dimensions

Orderable Device	Package Type	MPQ	MOQ	Eco Plan	MSL Level	Device Marking
ACM8628	TSSOP28 Tape and Reel	3000	3000	RoHS Compliant Lead-Free Finish	MSL3	ACM8628

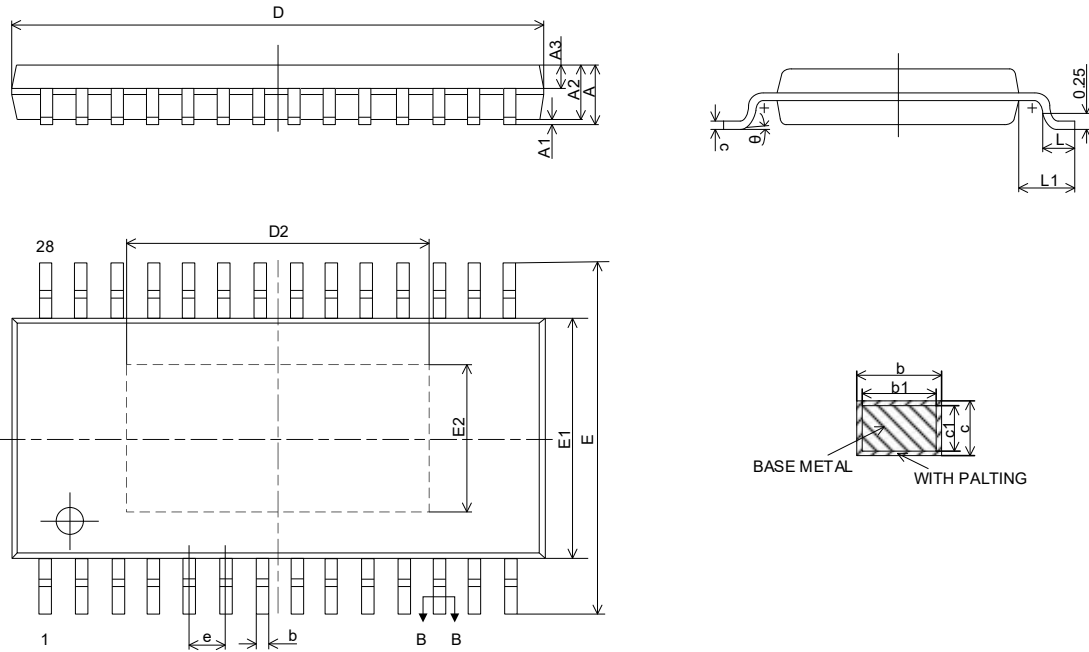

SYMBOL	MILLIMETER		
	MIN	NOM	MAX
A	—	—	1.20
A1	0.05	—	0.15
A2	0.80	—	1.00
A3	0.39	0.44	0.49
b	0.20	—	0.29
b1	0.19	0.22	0.25
c	0.13	—	0.18
c1	0.12	0.13	0.15
D	9.60	9.70	9.80
E	6.20	6.40	6.60
E1	4.30	4.40	4.50
e	0.65BSC		
L	0.45	0.60	0.75
L1	1.00BSC		
$\theta$	0	—	8°

L/F 载体尺寸 (mil)	D2	E2
232*118	5.50REF	2.70REF